

## INTRODUCTION TO ELECTRONICS

---

TEJ10- TIJ10  
Computer Engineering  
Summer 2022

This unit will allow students to work independently and collaboratively. Students will improve their technical skills through research and development of electricity, electronic components, basic wiring, basic circuit design and technical mathematics



# Table of Contents

---

Introduction .....	3
Project Outline.....	3
Prior Knowledge.....	3
Student Activities.....	4
Activity 1 –What is Electricity .....	4
Activity 2 –Electronic Components .....	5
Activity 3 –Resistors and how to classify them .....	6
Activity 4 –Electronic Labs.....	7
Activity 5 –Final Project .....	8
Planning Notes.....	9
Skilled Trades and Apprenticeship Opportunities.....	9
Skills Continuum.....	9
Career and Industry Extensions .....	10
Resources .....	11
Files .....	11
Lesson Plans.....	11
Handouts.....	11
Materials .....	11
Pictures/Exemplars of the Final Project .....	12
Instructional Strategies.....	12
The Hook / Motivational Strategies.....	12
Learning Goals and Success Criteria .....	13
Overall and Specific Expectations in Support of Ontario Curriculum Grades 9 - 10 Technological Education .....	13
Overall Expectations.....	13
Specific Expectations.....	14
Safety Concerns.....	14
Applicable SAFEDocs and ToolSAFE videos.....	14
Project Challenges .....	14
Differentiation of the Project / Activity.....	14
Assessment and Evaluation .....	15
Assessment As Learning .....	15

Assessment For Learning.....	15
Assessment Of Learning .....	15
Religious Considerations.....	15
Career and Industry Extensions .....	15
Ethical Considerations.....	16
Reflection or Design Report .....	16
Appendix A - What is Electricity Assignment?.....	17
Appendix B – TEJ 10 What is Electricity Quiz .....	19
Appendix C – TEJ 10 Electronic Components Search .....	23
Appendix D – TEJ 10 Resistor Worksheet .....	24
Appendix E – Resistors Colour Code Worksheet 2.....	26
Appendix F – TEJ 10 Resistor Quiz .....	28
Appendix G – Lab 1-The Resistor .....	32
Appendix H – Lab 2-The Diode .....	37
Appendix I – Lab 3-The Capacitor.....	43
Appendix J – Lab 4-The Potentiometer .....	48
Appendix K – Activity 1 What is Electricity Lesson Plan.....	54
Appendix L - Activity 2 –Electronic Components Lesson Plan .....	55
Appendix M - Activity 3 –Resistors and how to classify them Lesson Plan .....	56
Appendix N - Activity 4 –Electronic Labs Lesson Plan .....	58
Appendix O - Activity 5 –Final Project Lesson Plan.....	60
References.....	62

## Introduction

**Course Code:** TEJ 10

**Broad base Technology:** Introduction to Computer Engineering

**Destination:** Open

**Grade Level:** 9

**Prerequisite:** None

**Project Name:** Introduction to Electronics

## Project Outline

This unit will allow students to work independently and collaboratively. Students will improve their technical literacy skills through research and development of electricity, electronic components, basic wiring, basic circuit design and technical mathematics. Students will have the opportunity to engage collaboratively by working as a team to complete their final project, and or when they are building electronic circuits. This unit will also provide students with the opportunity to develop their comfort with “tinkering” and learning how things work via trial and error. Students will also have the chance to build a project that they can present to family and friends.

The major goals of this unit are to increase students' understanding of basic electronics, and how electricity is used to run simple circuitry that the students will build. Furthermore, students will sharpen their math skills while they are learning how to classify resistors and calculate resistance for a simple circuit. At the end of this unit, students will have mastered the concept of electricity, Voltage, Current and Resistance. Moreover, students will feel comfortable working around basic electronic components and know how they interact with the real world. Finally, the material covered in this unit will foster a level of excitement with further Computer Engineering concepts and other Computer Engineering courses in grade 10 to 12.

## Prior Knowledge

This is an introductory unit so no prior knowledge is required in order to complete this unit or the material within it.

## Student Activities

Students will learn about electricity, electronic components, including resistors, and perform an electronic lab and summative project.

### Activity 1 –What is Electricity

**Objective:** To become familiar with electricity, how it works, voltage, current, resistance and power. To learn how to use Ohm's law to calculate voltage, current and resistance.

#### Materials:

- A computer or copies of the presentation and assignments.
- calculator
- [What is Electricity PowerPoint](#)
- [What is Electricity Student Assignment](#)
- [What is Electricity Assignment Solution](#)
- [What is Electricity Assessment \(quiz\)](#)
- [What is Electricity Assessment Solution](#)

**Time:** 2-3 periods

The teacher will:

- Lead the students through the What is Electricity PowerPoint
- Go over the examples on Ohm's Law
- Allow students to explore a simple circuit as a picture and as a schematic.
- Allow students time to work. Circulate and provide feedback
- Assign and monitor the assignment. Possibly take up the assignment.
- Relate how electricity and Ohm's Law is used in our daily lives.

The students will:

- Learn about how electricity is created, moves, and its principal measurements: voltage, current, resistance and power.
- Practice multiplication and division concepts while they explore Ohm's Law.
- Understand the difference between voltage, current, resistance and power.
- Learn the 3 components all circuits must have to function.
- Examine and compare an electrical schematic of a circuit with a picture of an electrical circuit.

#### Assessment:

- What is electricity assignment
- What is electricity quiz?

## Activity 2 –Electronic Components

**Objective:** To become familiar with electrical components, their functions, what they physically look like, and how they are represented as an electronic schematic image. Students will also learn the difference between alternating current (AC power) and direct current (DC power) as well as how electricity is transported across our country.

### Materials:

- Computer or printed handouts of the PowerPoint and assignments
- access to the internet to complete the electronic components assignment
- [Assignment on electronic components](#)
- [Assignment on electronic components solutions](#)
- [Electronic Components PowerPoint](#)

**Time:** 2 periods

### Website Resources:

- [Google](#)

The teacher will:

- Give out and discuss the assignment on electronic components.
- Encourage the students to fully explain and learn about the specific electronic components in the assignment.
- Allow students time to work. Circulate and provide feedback
- Teach the material in the electronic components PowerPoint.

The students will:

- Learn about resistors, breadboards, capacitors, diodes, LED's and potentiometers.
- Learn the difference between AC and DC power, as well as how electricity is transported across the country.
- Be able to recognize the difference between an electrical schematic of a component versus a picture of the same electrical component.

### Assessment:

- Electronic Component assignment.

## Activity 3 –Resistors and how to classify them

**Objective:** To become familiar with resistors, how they work, and what they can do. Students will also learn how to classify a 3 and 4 band resistor.

### Materials:

- Computer or print outs of the PowerPoint, resistor classification table and handouts/assignments.
- [Resistors PowerPoint](#)
- [Resistor Worksheet 1](#)
- [Resistor Worksheet 1 Solutions](#)
- [Resistor Worksheet 2](#)
- [Resistor Quiz](#)
- [Resistor Quiz Solutions](#)
- [Resistor classification table](#)

**Time:** 2-3 periods

The teacher will:

- Lead the students through the Resistor PowerPoint
- Show the students how to properly classify a resistor using the PowerPoint and the resistor classification table.
- Give out and discuss the resistor worksheet 1 assignment.
- Give out and discuss the resistor worksheet 2 assignment.
- Allow students time to work. Circulate and provide feedback

The students will:

- Learn the different type of resistors
- Learn how to properly classify a 3 band and 4 band resistors.
- Practice how to classify a resistor and its tolerance.
- Understand the importance of a resistor in Computer Engineering and electronics.

Assessment:

- Resistor quiz.

## Activity 4 –Electronic Labs

**Objective:** To become familiar with building basic electronic circuits. To put into practice all the theory the students have learned in the unit.

### Materials:

- Computer or printed handouts of the labs.
- Online electronic circuit builder program ([www.tinkercad.com](http://www.tinkercad.com))
- School provided electronic circuit builder program (National Instruments LabView, Tina, Edison, Autodesk, for example.)
- If you are building the circuits with physical items, please see the material list on the labs. However, you will need at least the following equipment:
  - Electronic breadboard or prototyping breadboard
  - Power source and connectors.
  - Various wires for connecting components
  - LED's
  - Resistors, diodes, capacitors, potentiometers.
- [Lab 1 The Resistor Teacher Solution and Read Me](#)
- [Lab 1 The Resistor](#)
- [Lab 2 The Diode Teacher Solution and Read Me](#)
- [Lab 2 The Diode](#)
- [Lab 3 The Capacitor Teacher Solution and Read Me](#)
- [Lab 3 The Capacitor](#)
- [Lab 4 The Potentiometer Teacher Solution and Read Me](#)
- [Lab 4 The Potentiometer](#)

**Time:** 2-4 periods

The teacher will:

- Show the students how to properly set up a basic circuit so they have something to look at (exemplar)
- If using physical items, go over rules to use equipment, how to use it, and safe use. (You can reference [OCTE SAFEdocs](#)) for specific tools.
- If using an online or program for the labs, show the students how to use the software or online program.
- Allow students time to work. Circulate and provide feedback

The students will:

- Read through the labs before they begin working on them.
- Follow the teacher's instructions as to what materials they will be using and how to use them correctly.
- Students should tinker and experiment with the electronic components.
- Appreciate the intricacies of building and interacting with electronic components.

Assessment:

- The 4 labs or any combination of the labs you wish to collect and assess.

## Activity 5 –Final Project

**Objective:** The final project consists of an activity where the students can either on their own, or in groups build or decorate some type of device or item using their electronics knowledge. If it is Easter, have the students light up something that represents Easter. If it is Halloween, have the students light up or decorate pumpkins (plastic) or any other type of Halloween decoration. If it is Christmas, have them light up or decorate some type of Christmas decoration. You can modify my examples to suit any topic, time of year, or item based on your students. See example project ideas [Easter Egg Electronics Project](#), [Easter Tin Electronics Project](#), [Halloween Electronics Project](#), [Halloween Plastic Project](#), [Halloween Plastic bucket Electronics Project](#)

### **Materials:**

- A computer or the specific handout based on your idea.
- Physical electronic equipment if the students are going to physically build an item.

**Time:** 2-3 periods

The teacher will:

- If using physical items, make sure they are laid out and ready for the students.
- Allow students time to work. Circulate and provide feedback
- Encourage the students to tinker and experiment with the electronic components.

The students will:

- Read through the labs before they begin working on them.
- Follow the teacher’s instructions as to what materials they will be using and how to use them correctly.
- Put equipment back in the correct location when you are done with it.
- Appreciate the intricacies of building and interacting with electronic components.

### **Assessment:**

- The final product that the student creates.

## Planning Notes

Most of the activities in this unit are set up to be run in a standard Socratic method. You lead with a lesson on the material (PowerPoint), then work(assignment, homework, etc.) to help reinforce the material. Finally, most of the activities have some form of formal assessment, or you can use the assignments for assessment. Evaluation and learning skills can be recorded while you are observing the students working on the material. However, the last 2 lessons involve the students actually building and using the knowledge they have learned from the first 3 activities. In activity 4 you have 2 options, you can either have the students build the circuits in an online program, or if your school has some type of electronics software. Or if you have electrical equipment then you can have the students physically build the circuits. If you go the software route you will need to teach the students how to use the software this could take 1-3 classes to do. If you are using physical equipment you will need to teach how to use the material safely and set up protocols for handling, removing and putting away the equipment. OCTE ToolSAFE or SAFEdocs will be able to help you prepare your students to use the equipment safely. Activity 5 is also a hands-on activity and I have found that when you show the final project the students have made to the school community it really “fires up” the students in a positive way. Prior to the unit teachers may wish to give a lesson on group work norms.

## Skilled Trades and Apprenticeship Opportunities

- Industrial Electrician
- Industrial Mechanic (Millwright)
- Instrumentation and Control Technician
- Electrical Equipment Inspector
- Electronic Products Designer
- Electrical Engineering Technologist
- Capacitor assembler
- Component inserting machine operator
- Electronics tester
- ESA Inspector

## Skills Continuum

As students pursue their careers in the Computer Engineering technology industry, they will have opportunities to build on the skills learned during this unit, as the curriculum expectations met during this project are aligned with many curriculum expectations in Computer Science and Computer Engineering

We all have different moments in our lives where we are affected by an experience. This can include learning a new concept or skill, experiencing something for the first time, taking a new course, developing a talent through practice and hard work, or even calling upon a skilled tradesperson to fix, repair, design, construct, maintain, build, bake, and create innovative solutions. The continuum of influence is a graphic representation of how those experiences can lead to developing a passion and talents in areas of technology and skilled trades as an industrial electrician, industrial mechanic (millwright), instrumentation and control technician, electrical equipment inspector, electronic products designer, electronics technician, etc.

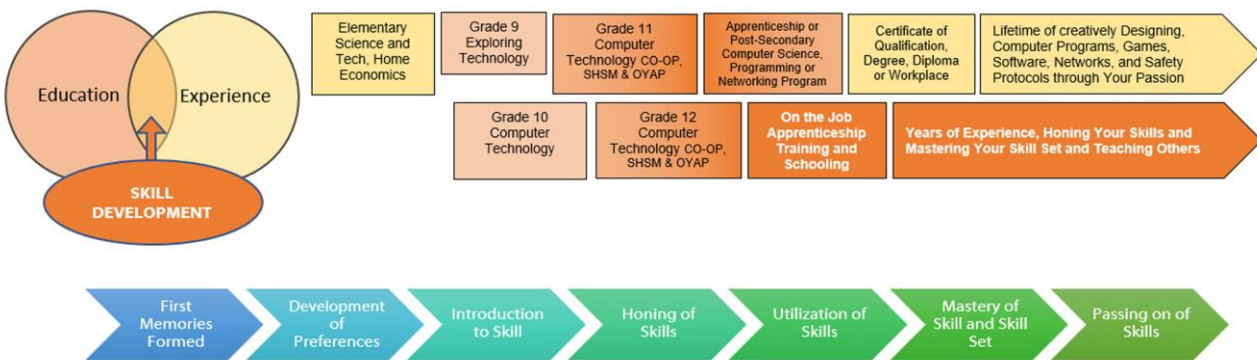

## Career and Industry Extensions

Students can explore career connections and opportunities in the following fields:

- Computer Design and Engineering — Design new computer circuits, microchips, and other electronic components.
- Computer Architecture — Design new computer instruction sets and combine electronic or optical components to provide powerful but cost-effective computing.
- Information Technology — Develop and manage information systems that support a business or organization.
- Software Engineering — Develop methods for the production of software systems on time, within budget, and with few or no defects.
- Operating Systems and Networks — Develop the basic software computers use to supervise themselves or to communicate with other computers.
- Software Applications — Apply computing and technology to solving problems outside the computer field – in education or medicine, for example.
- Robotics - Build robots to solve problems facing humankind.

# Resources

## Files

What is Electricity? [Assignment](#) and [Answer Sheet](#) (see Appendix A)

TEJ What is Electricity [Quiz](#) and [Answer Sheet](#) (see Appendix B)

TEJ 10 Electronic Components Search (see Appendix C)

TEJ 10 Resistor [Worksheet](#) and [Answer Sheet](#) (see Appendix D)

Resistors Colour Code [Worksheet 2](#) (see Appendix E)

TEJ 10 Resistor [Quiz](#) with [Answer Sheet](#) (see Appendix F)

Lab 1-The Resistor [Lab](#) with [Answer Sheet](#) (see Appendix G)

Lab 2-The Diode [Lab](#) with [Answer Sheet](#) (see Appendix H)

Lab 3-The Capacitor [Lab](#) with [Answer Sheet](#) (see Appendix I)

Lab 4-The Potentiometer [Lab](#) with [Answer Sheet](#) (see Appendix J)

## Lesson Plans

Activity 1 What is Electricity Lesson Plan (see Appendix K)

Activity 2 –Electronic Components Lesson Plan (see Appendix L)

Activity 3 –Resistors and how to classify them Lesson Plan (see Appendix M)

Activity 4 –Electronic Labs Lesson Plan (see Appendix N)

Activity 5 –Final Project Lesson Plan (see Appendix O)

## Handouts

Handouts or worksheets are linked in the Activities listed above.

## Materials

Many of the activities and lessons require bread boards, switches, potentiometers, resistors, capacitors, wires, batteries or an energy source. Please see the labs for a list of specific and required materials.

## Pictures/Exemplars of the Final Project

Here are some images of previous final projects done by my students:



- [Coffins](#)
- [Easter Bunny](#)
- [Easter Image 1](#)
- [Easter Image 2](#)
- [Easter Image 3](#)
- [Fuzzy Pumpkin](#)
- [Halloween 1](#)
- [Halloween 2](#)
- [Skeleton Nuclear Waste](#)
- [Spooky Bucket](#)

## Instructional Strategies

Teachers may use any of the following instructional strategies; 3-Part lesson, lecture, storyboard, word wall, think-pair-share, placemat activity, rapid write, K-W-L, anticipation chart, ABC taxonomy, think aloud, analyzing text, Cornell note taking, exit ticket/ticket out the door, plus/minus/delta, etc.

## The Hook / Motivational Strategies

Encouraging students to explore the concepts and then see how the concepts relate to real world problems will increase the interest and motivation of the students. Furthermore, having the students share what they built with friends and family as well as the school community will also motivate students to learn and explore. Also, by connecting with other classmates in a team and engaging in kinesthetic learning will help with student motivation. Finally, students naturally are intuitive and like to explore and play, so encouraging them to play and explore will foster excitement and motivate the students to learn.

## Learning Goals and Success Criteria

Learning goals and success criteria are the foundation on which students base their ability to monitor their learning and determine next steps. Applicable learning goals may include any of the following,

- Students will learn about the various electronic products and items.
- Students will gain knowledge of content (e.g., math facts, computational strategies, terminology, Ohm's law, current, voltage, resistance, AC power, DC power )
- Students will demonstrate an understanding of content (e.g., concepts, theories, procedures, principles, mathematical processes)

Success criteria may include any of the following,

- I will be able to identify different measurements and how to calculate them.
- I will be able to understand the benefits of electricity and how it is used in life.
- I will be more comfortable building and experimenting with basic electronic circuits.
- I will be able to classify a 3 or 4 band resistor.

Teachers may use the [Learning Goals and Success Criteria Viewing Guide](#) as a resource should they require assistance

## Overall and Specific Expectations in Support of Ontario Curriculum Grades 9 - 10 Technological Education

### Overall Expectations

**A1.** Identify and describe the functions of, as well as important advances related to, electronic and computer components;

**B2.** Construct and test simple interfaces and other electronic circuits;

**C2.** Identify effects of the widespread use of computers and associated technologies on society

## Specific Expectations

**A1.1** Identify basic electronic components and describe their functions (e.g., resistors limit current; capacitors store charge, pass high frequencies, and block DC; diodes restrict current in one direction; LEDs indicate current flow; transistors act as amplifiers or switches)

**B2.1** Safely construct and test electronic circuits (e.g., LED circuit, flasher, timer), using both breadboard and soldering techniques to connect discrete components and/or integrated circuits;

**C2.1** Identify some of the effects of the development of computer technology on society

## Safety Concerns

If the students are using tools or equipment, they must have the proper training before they engage in the activities. When students are engaged in practical lab activities or in shops, school board safety may also include wearing the proper personal protective equipment such as safety glasses. Check your school board's safety protocols so you are compliant.

## Applicable SAFEDocs and ToolSAFE videos

Please refer to the [OCTE SAFEDocs for BBT Technology](#) for safety documents in order to properly address and instruct this project.

- [ToolSAFE TEJ Electronic Circuit Designing](#)
- [ToolSAFE TEJ Wire Stripping and Crimping](#)
- [SafetyNET TEJ Breadboard And Circuits Lab](#)

## Project Challenges

The final project or CPT (Culminating Project Task) can be altered or modified in many different ways. You can modify my examples to suit any topic, time of year, or item based on your students.

## Differentiation of the Project / Activity

- Working in groups, have students teach one another.
- If students are online, they can create the labs in an online application like Tinkercad.

Teachers can also refer to the [Differentiation Scrapbook](#) to take into account for learner ability, multiple intelligences, exceptional students, and ESL learners.

# Assessment and Evaluation

## Assessment As Learning

- Ask questions and make suggestions based on observation
- Assess students' cognition about their learning (asking them “Why” and “How” they are completing a certain operation)
- Students monitor their own learning and ask questions as needed

## Assessment For Learning

- Provide feedback to students about their learning and how to improve
- Create differentiated teaching strategies and learning opportunities
- Identify particular learning needs of students

## Assessment Of Learning

- Students will complete quizzes to assess their understanding of the lessons
- Students will complete assignments and/or homework questions.
- Students will complete 4 electronics labs.

## Religious Considerations

The final project can be used to celebrate a religious holiday or event. Please take into consideration any religious celebrations and events that could be incorporated with this instructional activity and final project.

## Career and Industry Extensions

- Students can sign up for robotic boot camps or they can apply for skills Canada events.
- Students can join Raspberry Pi, Arduino clubs or groups to extend their learned skills.
- Students can look for co-op opportunities with an employer where they can acquire new skills and hone their own skills.

## Ethical Considerations

The purposes of the ethical considerations and standards are to inspire members to care, provide respect, develop trust and integrity. Participants should be able to reflect on the learning and identify responsibilities and make ethical decisions.

## Reflection or Design Report

Teachers should have the students Create and complete designs on the various templates they have and write a report/reflection on their learning. This would be a nice way to capture the student's understanding in a summative format and be used in preparation for their examination, entering post-secondary education or the workforce.

## Appendix A - What is Electricity Assignment?

**Instructions:** Use what you have learned from the What is Electricity assignment to answer the following Ohms Law questions. Fill in the blanks in the table, the missing value (V,I,R) Do not forget to include the units, or the answer is incorrect.

(A) I Current	( $\Omega$ ) R Resistance	(V) V Voltage
10 A	30 $\Omega$	?
?	2 $\Omega$	20 V
20 A	?	120 V
4 A	?	60 V
35 A	10000 $\Omega$	?
?	20 $\Omega$	1000 V
30 A	?	16 V
11 mA	9 $\Omega$	?
?	5 $\Omega$	100000 V
90 mA	?	20 V
3 A	1 K $\Omega$	?
20 mA	?	12 V
?	470 $\Omega$	9 V
120 mA	560 $\Omega$	?
8000 mA	?	68 V
?	220 $\Omega$	3.3V
200 A	12 $\Omega$	?
?	1000 $\Omega$	100 V

## What is Electricity Assignment? (Answer Sheet)

**Instructions:** Use what you have learned from the What is Electricity assignment to answer the following Ohms Law questions. Fill in the blanks in the table, the missing value (V,I,R) Do not forget to include the units, or the answer is incorrect.

(A) I Current	( $\Omega$ ) R Resistance	(V) V Voltage
10 A	30 $\Omega$	300 V
10 A	2 $\Omega$	20 V
20 A	6 $\Omega$	120 V
4 A	15 $\Omega$	60 V
35 A	10000 $\Omega$	350000 V
50 A	20 $\Omega$	1000 V
30 A	0.53333333 $\Omega$	16 V
11 mA	9 $\Omega$	0.099 V
20000 A	5 $\Omega$	100000 V
90 mA	222.22 $\Omega$	20 V
3 A	1 K $\Omega$	3000 V
20 mA	600 $\Omega$	12 V
19.1 mA	470 $\Omega$	9 V
120 mA	560 $\Omega$	67.2 V
8000 mA	8.5 $\Omega$	68 V
0.15 mA	220 $\Omega$	3.3V
200 A	12 $\Omega$	2400 V
100 mA	1000 $\Omega$	100 V

## Appendix B – TEJ 10 What is Electricity Quiz

Name: \_\_\_\_\_

K/U /7

Comm /4

Application /6

**Answer the following question below. (K/U)**

An item that lets electron's jump around very easily is called a \_\_\_\_\_.

2. Current (I) is measured in \_\_\_\_\_

3. Voltage is measured in \_\_\_\_\_

4. All circuits consist of three parts. The 3 parts are:

- 1.
- 2.
- 3.

5. An example of a power source would be a : \_\_\_\_\_

**Answer the following questions using examples and full sentences.  
(Communication)**

1. What is the difference between Voltage and Amperage? (2 marks)

2. Give an example using a straw that describes how resistance works based on the lesson. (2 marks)

**Answer the following Ohms Law questions. Do not forget your units. (Application)  
Formulas**

$$V = I \times R$$

$$R = V \div I$$

$$I = V \div R$$

1. I have a simple circuit with an LED that needs 20 mA of current, and a 9 V battery. How much resistance would I need for this circuit? (2 marks 1 answer, 1 for unit)

$$R = 9 / .02 \text{ (remember change to amps)}$$

$$R = 450 \Omega$$

2. I have a simple circuit with an LED that needs 20 mA of current, and I have a 1000 ohm resistor. How much voltage would I need for this circuit? (2 marks 1 answer, 1 for unit)

$$V = 0.02 \times 1000$$

$$V = 20 \text{ V}$$

3. What type of current would I need if I built a circuit that consisted of a 12 ohm resistor and a 36 V battery? (2 marks 1 answer, 1 for unit)

$$I = 36 / 12$$

$$I = 3 \text{ A}$$

## TEJ 10 What is Electricity Quiz Answer Sheet

Name: \_\_\_\_\_

K/U /7                      Comm /4                      Application /6

Answer the following question below. (K/U)

An item that lets electron's jump around very easily is called a Conductor.

2. Current (I) is measured in Amps

3. Voltage is measured in Volts

4. All circuits consist of three parts. The 3 parts are:

1. Source
2. Load
3. Path

5. An example of a power source would be a : battery

Answer the following questions using examples and full sentences. (Communication)

1. What is the difference between Voltage and Amperage? (2 marks)

Voltage is the speed of the electrons, while amperage is the intensity or quantity of electrons in the wire.

2. Give an example using a straw that describes how resistance works based on the lesson. (2 marks)

By squeezing the straw, I am restricting how quickly the liquid I am drinking will move.

**Answer the following Ohms Law questions. Do not forget your units. (Application)  
Formulas**

$$V = I \times R$$

$$R = V \div I$$

$$I = V \div R$$

1. I have a simple circuit with an LED that needs 20 mA of current, and a 9 V battery. How much resistance would I need for this circuit? (2 marks 1 answer, 1 for unit)

$$R = 9 / .02 \text{ (remember change to amps)}$$

$$R = 450 \Omega$$

2. I have a simple circuit with an LED that needs 20 mA of current, and I have a 1000 ohm resistor. How much voltage would I need for this circuit? (2 marks 1 answer, 1 for unit)

$$V = 0.02 \times 1000$$

$$V = 20 \text{ V}$$



3. What type of current would I need if I built a circuit that consisted of a 12 ohm resistor and a 36 V battery? (2 marks 1 answer, 1 for unit)

$$I = 36 / 12$$

$$I = 3 \text{ A}$$

## Appendix C – TEJ 10 Electronic Components Search

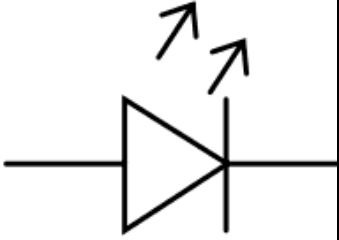
**Instructions:** Make a chart with 4 columns and 8 rows in any word processing software. I have completed the first one for you.

Component	Function	Schematic	Picture
Name of component	Tell me what it does	Technical drawing of item	What it actually looks like.
LED	Takes electricity and turns it to light.		

Enter the headings component (name of the item (from the list below)), function, (what it does/how it works) schematic (how it is represented on technical drawings) and finally a picture. Use one row for each of the components below:

Resistor  
 NPN transistor  
 PNP transistor  
 Capacitor  
 Diode  
 Potentiometer

You may use any type of website or resource to fill in the chart that you have made. Be sure to spell check, grammar check and make sure your images fit in the column.

## Appendix D – TEJ 10 Resistor Worksheet

Using the resistor chart below as a guide, answer the questions below.

Resistor Colour Code Chart			
Colour	1 <sup>st</sup> Number	2 <sup>nd</sup> Number	3 <sup>rd</sup> Number
Black	0	0	No zero
Brown	1	1	0
Red	2	2	00
Orange	3	3	000
Yellow	4	4	0000
Green	5	5	00000
Blue	6	6	000000
Violet	7	7	0000000
Grey	8	8	00000000
White	9	9	000000000
4 <sup>th</sup> band	Gold +/- 5%	Silver +/- 10%	No Band +/- 20%

Determine the value of the following resistors Value (Ohms)

- 1) brown, red, red, gold
- 2) violet, blue, yellow, silver
- 3) green, black, black, no band
- 4) yellow, violet, orange, gold
- 5) grey, green, silver
- 6) red, red, black, gold
- 7) orange, black, black, silver
- 8) blue, violet, orange, no band
- 9) brown, black, orange, gold
- 10) green, yellow, red, silver

Determine the correct colour code given the resistor value. (Do not worry about the tolerance for these examples)

Resistor Value (Ohms)	Band 1	Band 2	Band 3
330			
220			
6900			
50000			
330K			
560K			
470			
1.2K			
680K			
1K			

## TEJ 10 Resistor Worksheet Answer Sheet

Using the resistor chart below as a guide, answer the questions below.

Resistor Colour Code Chart			
Colour	1 <sup>st</sup> Number	2 <sup>nd</sup> Number	3 <sup>rd</sup> Number
Black	0	0	No zero
Brown	1	1	0
Red	2	2	00
Orange	3	3	000
Yellow	4	4	0000
Green	5	5	00000
Blue	6	6	000000
Violet	7	7	0000000
Grey	8	8	00000000
White	9	9	000000000
4 <sup>th</sup> Ring	Gold +/- 5%	Silver +/- 10%	No Band +/- 20%

A. Determine the value of the following resistors

- |                                  |                             |
|----------------------------------|-----------------------------|
| 1) Brown, red, Red, Gold         | Value (Ohms)<br>1200 Ω ± 5% |
| 2) Violet, Blue, Yellow, Silver  | 760000 Ω ± 10%              |
| 3) Green, Black, Black, No Band  | 50 Ω ± 20%                  |
| 4) Yellow, Violet, Orange, Gold  | 47000 Ω ± 5%                |
| 5) Grey, Green, Silver           | 8800000 Ω ± 10%             |
| 6) Red, red, Black, Gold         | 22 Ω ± 5%                   |
| 7) Orange, Black, Black, Silver  | 30 Ω ± 10%                  |
| 8) Blue, Violet, Orange, No Band | 67000 Ω ± 20%               |
| 9) Brown, Black, Orange, Gold    | 10000 Ω ± 5%                |
| 10) Green, Yellow, red, Silver   | 5400 Ω ± 10%                |

B. Determine the correct colour code given the resistor value.

Resistor Value (Ohms)	Band 1	Band 2	Band 3
330	Orange	Orange	Brown
220	Red	Red	Brown
6900	Blue	White	Red
50000	Green	Black	Orange
330K	Orange	Orange	Yellow
560K	Green	Blue	Yellow
470	Yellow	Violet	Brown
1.2K	Brown	Red	Red
680K	Blue	Grey	Yellow
1K	Brown	Black	Red

## Appendix E – Resistors Colour Code Worksheet 2

Name: \_\_\_\_\_

Colour Code Resistor Table for Classifying 3 Stripe Resistors				
Colour	1 <sup>st</sup> Number	2 <sup>nd</sup> Number	3 <sup>rd</sup> Number	Tolerance (4 <sup>th</sup> band)
Black	0	0	No Zero	A fourth band can be added to the far side of the resistor. You can have a Silver, Gold, or No Band. This 4 <sup>th</sup> band is the tolerance of the resistor. Think of it as a buffer that the resistor can work with.
Brown	1	1	0	
Red	2	2	00	
Orange	3	3	000	
Yellow	4	4	0000	
Green	5	5	00000	
Blue	6	6	000000	
Violet	7	7	0000000	
Grey	8	8	00000000	
White	9	9	000000000	
No 4 <sup>th</sup> Band				+/-20%
Silver				+/-10%
Gold				+/-5%

Resistor	Band 1	Band 2	Band 3	Band 4
820 $\Omega$ $\pm$ 10%				
560000 $\Omega$ $\pm$ 10%				
150 $\Omega$ $\pm$ 20%				
330000 $\Omega$ $\pm$ 10%				
5100 $\Omega$ $\pm$ 5%				
10 $\Omega$ $\pm$ 10%				
12 $\Omega$ $\pm$ 10%				
510 $\Omega$ $\pm$ 20%				
1200000 $\Omega$ $\pm$ 5%				
270 $\Omega$ $\pm$ 20%				
4700000 $\Omega$ $\pm$ 10%				
75000 $\Omega$ $\pm$ 10%				

Colour Code Resistor Table for Classifying 3 Stripe Resistors				
Colour	1 <sup>st</sup> Number	2 <sup>nd</sup> Number	3 <sup>rd</sup> Number	Tolerance (4 <sup>th</sup> band)
Black	0	0	No Zero	A fourth band can be added to the far side of the resistor. You can have a Silver, Gold, or No Band. This 4 <sup>th</sup> band is the tolerance of the resistor. Think of it as a buffer that the resistor can work with.
Brown	1	1	0	
Red	2	2	00	
Orange	3	3	000	
Yellow	4	4	0000	
Green	5	5	00000	
Blue	6	6	000000	
Violet	7	7	0000000	
Grey	8	8	00000000	
White	9	9	000000000	
No 4 <sup>th</sup> Band				+/-20%
Silver				+/-10%
Gold				+/-5%

47 Ω ± 5%				
2200000 Ω ± 20%				
10000 Ω ± 10%				
7500 Ω ± 5%				
330000 Ω ± 5%				
75 Ω ± 5%				
82000 Ω ± 20%				
6800000 Ω ± 10%				
51 Ω ± 10%				
27 Ω ± 20%				
6800 Ω ± 10%				
470 Ω ± 5%				
270000 Ω ± 10%				

## Appendix F – TEJ 10 Resistor Quiz

Name: \_\_\_\_\_

Application /30

In the space below, answer the following questions about resistors. Give me the amount of resistance, and the tolerance of the resistor. For example, blue, blue, black, silver would be 66 ohms +/- 10% or 66  $\Omega$  +/- 10%

	<b>BAND 1</b>	<b>BAND 2</b>	<b>BAND 3</b>
<b>Black</b>	0	0	No zero's
<b>Brown</b>	1	1	0
<b>Red</b>	2	2	00
<b>Orange</b>	3	3	000
<b>Yellow</b>	4	4	0000
<b>Green</b>	5	5	00000
<b>Blue</b>	6	6	000000
<b>Violet</b>	7	7	0000000
<b>Grey</b>	8	8	00000000
<b>White</b>	9	9	000000000

**Tolerance: No colour +/- 20%, Silver +/- 10%, Gold +/- 5%.**

1. I have a resistor, and the band colour is Black, Red, Blue. What is its value, and what is its tolerance? (2 marks)
  
2. I have a resistor, and the band colour is Blue, Violet, Grey, Silver. What is its value, and what is its tolerance? (2 marks)
  
3. I have a resistor, and the band colour is Yellow, White, Green, Gold. What is its value, and what is its tolerance? (2 marks)

4. I have a resistor, and the band colour is Violet, White, Grey, Gold. What is its value, and what is its tolerance? (2 marks)

5. I have a resistor, and the band colour is Blue, Yellow, White. What is its value, and what is its tolerance? (2 marks)

6. I have a resistor, and the band colour is Red, Yellow, White, Silver. What is its value, and what is its tolerance? (2 marks)

### Resistor Colour Code Chart

	BAND 1	BAND 2	BAND 3
<b>Black</b>	0	0	1
<b>Brown</b>	1	1	10
<b>Red</b>	2	2	100
<b>Orange</b>	3	3	1 000
<b>Yellow</b>	4	4	10 000
<b>Green</b>	5	5	100 000
<b>Blue</b>	6	6	1 000 000
<b>Violet</b>	7	7	10 000 000
<b>Grey</b>	8	8	100 000 000
<b>White</b>	9	9	1 000 000 000

**Tolerance: No colour 20%, Silver 10%, Gold 5%.**

Determine the correct colour code given the resistor value. (Put the colour in the correct box) (18 marks, 1 mark per box)

Resistor Value (Ohms)	Band 1 (colour)	Band 2 (colour)	Band 3 (colour)
220			
6900			
330K			
560K			
470			
12K			

## TEJ 10 Resistor Quiz Answer Sheet

Name: \_\_\_\_\_

Application /30

In the space below, answer the following questions about resistors. Give me the amount of resistance, and the tolerance of the resistor. For example, blue, blue, black, silver would be 66 ohms +/- 10% or  $66 \Omega \pm 10\%$

	BAND 1	BAND 2	BAND 3
<b>Black</b>	0	0	No zero's
<b>Brown</b>	1	1	0
<b>Red</b>	2	2	00
<b>Orange</b>	3	3	000
<b>Yellow</b>	4	4	0000
<b>Green</b>	5	5	00000
<b>Blue</b>	6	6	000000
<b>Violet</b>	7	7	0000000
<b>Grey</b>	8	8	00000000
<b>White</b>	9	9	000000000

**Tolerance: No colour +/- 20%, Silver +/- 10%, Gold +/- 5%.**

1. I have a resistor, and the band colour is Black, Red, Blue. What is its value, and what is its tolerance? (2 marks)

2 000 000 ohm or  $2M \Omega \pm 20\%$

2. I have a resistor, and the band colour is Blue, Violet, Grey, Silver. What is its value, and what is its tolerance? (2 marks)

6 700 000 000 ohm or  $6.7G\Omega \pm 10\%$

3. I have a resistor, and the band colour is Yellow, White, Green, Gold. What is its value, and what is its tolerance? (2 marks)

4 900 000 ohm or  $4.9M\Omega \pm 5\%$

4. I have a resistor, and the band colour is Violet, White, Grey, Gold. What is its value, and what is its tolerance? (2 marks)

7 900 000 000 ohm or 7.9GΩ +- 5%

5. I have a resistor, and the band colour is Blue, Yellow, White. What is its value, and what is its tolerance? (2 marks)

64 000 000 000 ohm or 64GΩ +-20%

6. I have a resistor, and the band colour is Red, Yellow, White, Silver. What is its value, and what is its tolerance? (2 marks)

24 000 000 000 ohm or 24GΩ +-10%

### Resistor Colour Code Chart

	BAND 1	BAND 2	BAND 3
<b>Black</b>	0	0	1
<b>Brown</b>	1	1	10
<b>Red</b>	2	2	100
<b>Orange</b>	3	3	1 000
<b>Yellow</b>	4	4	10 000
<b>Green</b>	5	5	100 000
<b>Blue</b>	6	6	1 000 000
<b>Violet</b>	7	7	10 000 000
<b>Grey</b>	8	8	100 000 000
<b>White</b>	9	9	1 000 000 000

**Tolerance: No colour 20%, Silver 10%, Gold 5%.**

Determine the correct colour code given the resistor value. (Put the colour in the correct box) (18 marks, 1 mark per box)

Resistor Value (Ohms)	Band 1 (colour)	Band 2 (colour)	Band 3 (colour)
220	Red	Red	Black
6900	Blue	White	Red
330K	Orange	Orange	Yellow
560K	Green	Blue	Yellow
470	Yellow	Violet	Brown
12K	Brown	Red	Orange

## Appendix G – Lab 1-The Resistor

**Purpose:** In this lab the student either alone or in partners (depending on how much electronic equipment you have) will work to learn the effect of resistors in an electrical circuit.

**Materials:**

1. Breadboard
2. Power supply
3. A 100 ohm resistor
4. A 10000 ohm resistor
5. 1 Light emitting Diode (LED)
6. Various wires
7. Various resistors

**Procedure:**

1. Set up your circuit either using physical items supplied by your teacher or on your device. (Use the example below to assist you)
2. Use a 100 ohm resistor first when you set up your circuit.
3. Make an observation on the brightness of your LED. (Bright, dim, really bright, really dim, etc..) use the chart below for this.
4. Replace the 100 ohm resistor with the 10000 ohm resistor.
5. Make an observation on the brightness of your LED. (Bright, dim, really bright, really dim, etc..) use the chart below for this.
6. Using the various resistors supplied by your teacher, replace the 10000 ohm resistor with each supplied resistor and make an observation on the brightness of your LED.  
(Bright, dim, really bright, really dim, etc.) Use the chart below for this.
7. Once you have filled in your table, summarize and make a conclusion (at the end of this lab) on the relationship between the value of a resistor and how it affects the brightness of an LED.

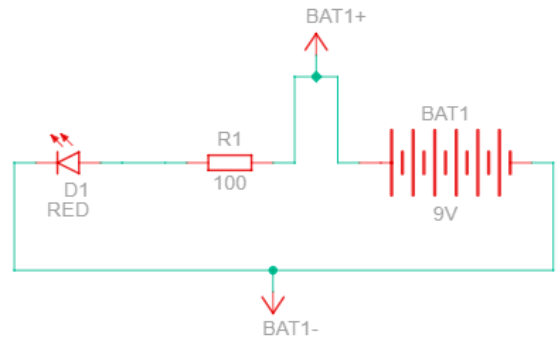
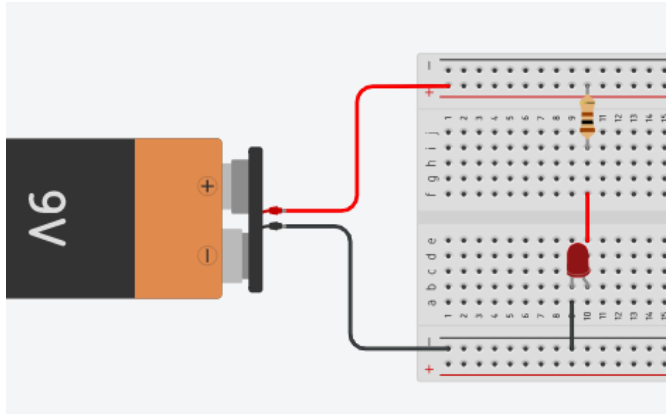

**Observations:**

Value of Resistor	Brightness of the light
100 $\Omega$	
10000 $\Omega$	

**Conclusion:**

## Notes for the Teacher

If you are having the students do this lab online in something like Tinkercad or another type of software, some students will find it very difficult to see the difference in brightness as they go from like 10000, to 50000, to 100000 ohms. However, they will definitely see the difference between the 100 and 10000 ohm resistor.

If you have breadboards, wires, and batteries, you will want to make sure that a student must always use a resistor between the battery and LED, as a 9V battery will burn out a standard LED if you do not put a resistor between them.

Also, if you are doing this physically, make sure your students DO NOT leave the LED's running for a long period of time, especially with the lower resistance values, this will prevent your LED's from burning out, getting hot, and not drain your batteries.

Common mistakes made by students in this lab: Often students will not put the wires in the correct holes on the breadboard. If you look at this example: The resistor is connected to the +ve top rail of the breadboard, and then the bottom of the resistor is inserted in row I, column 10. The red wire that connects the resistor to the LED is inserted at row f column 10. The red wire then goes over the breadboard, and connects to row e column 10, which is where the Positive (Anode) leg of the LED is. If you do not line it up like this, your circuit will not work. Finally, the negative (cathode) leg of the LED is in row b column 9. You cannot insert an LED's 2 legs into the same column, as that will not allow a path in the circuit. Finally, the ground wire at row A column 9 is grounded in the bottom negative rail of the breadboard. All these details matter, as electricity must have a clear path that goes from the source back to the source.

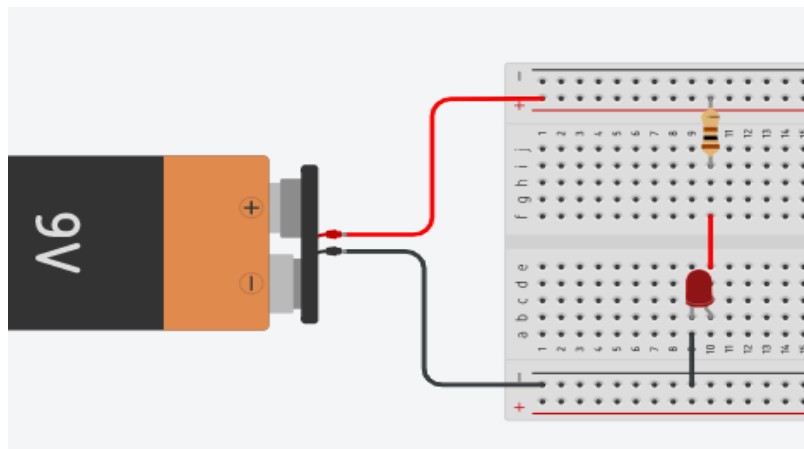

If you students are building the circuit in real life, the long led of the LED must get the power, and the short leg must go to ground, as an LED has polarity. A resistor does not, so the orientation of the resistor in the breadboard does not matter.

## Lab 1-The Resistor Answers

**Purpose:** In this lab the student either alone or in partners (depending on how much electronic equipment you have) will work to learn the effect of resistors in an electrical circuit.

**Materials:**

1. Breadboard
2. Power supply
3. A 100 ohm resistor
4. A 10000 ohm resistor
5. 1 Light emitting Diode (LED)
6. Various wires
7. Various resistors

**Procedure:**

1. Set up your circuit either using physical items supplied by your teacher or on your device. (Use the example below to assist you)
2. Use a 100 ohm resistor first when you set up your circuit.
3. Make an observation on the brightness of your LED. (Bright, dim, really bright, really dim, etc..) use the chart below for this.
4. Replace the 100 ohm resistor with the 10000 ohm resistor.
5. Make an observation on the brightness of your LED. (Bright, dim, really bright, really dim, etc..) use the chart below for this.
6. Using the various resistors supplied by your teacher, replace the 10000 ohm resistor with each supplied resistor and make an observation on the brightness of your LED.  
(Bright, dim, really bright, really dim, etc.) Use the chart below for this.
7. Once you have filled in your table, summarize and make a conclusion (at the end of this lab) on the relationship between the value of a resistor and how it affects the brightness of an LED.

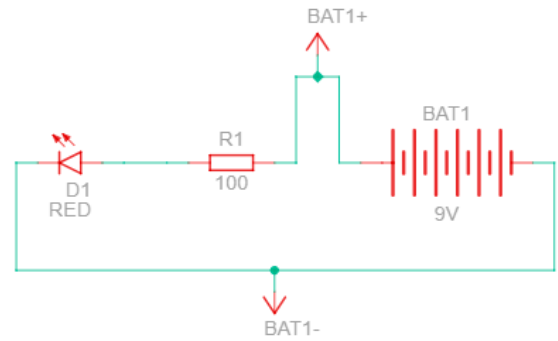
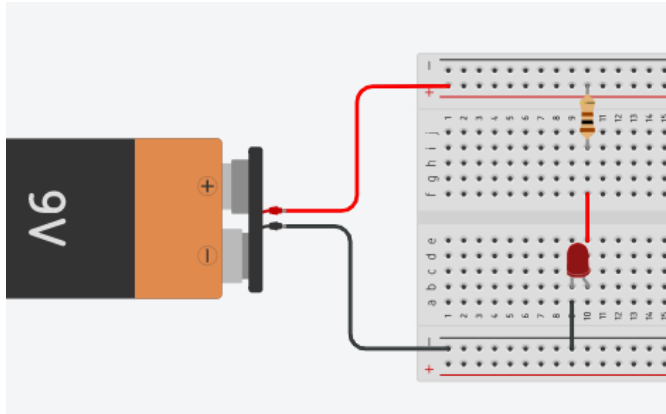

**Observations:**

Value of Resistor	Brightness of the light
100 $\Omega$	Very bright
10000 $\Omega$	Very dim

**Conclusion:** As the value of the resistor goes up, the level of brightness will go down. This is because the resistor will decrease the amount of electrons flowing to the LED, and as such, reduces the energy or power going into the LED.

## Appendix H – Lab 2-The Diode

**Purpose:** In this lab the student either alone or in partners (depending on how much electronic equipment you have) will discover the concept of polarity and the properties of several electronic components.

**Materials:**

1. Breadboard
2. Power supply
3. A 100 ohm resistor
4. A 1N 4001 Diode
5. 1 Light emitting Diode (LED)
6. Various wires

**Procedure:**

1. Set up your circuit either using physical items supplied by your teacher or on your device. (Use the example below to assist you)
2. Use a 100 ohm resistor first when you set up your circuit.
3. When you insert your diode into your circuit make sure the end that has the silver strip, is going into the positive (anode) or long leg of the LED. (This is very important)
4. Make an observation on whether or not your LED is on or off. Use the chart below for this.
5. Now, flip your **resistor** 180 degrees. In other words, switch the bottom part of the resistor (row I col 10) with the top rail (where the red wire comes in) and take the top of your resistor and place it in row I col 10.
6. Record what happens to the LED in the table below.
7. Finally flip your Diode 180 degrees, so the silver strip is closer to the resistor. Record your results in the table below.
8. Now, flip your **resistor** 180 degrees. In other words, switch the bottom part of the resistor (row I col 10) with the top rail (where the red wire comes in) and take the top of your resistor and place it in row I col 10.
9. Record your results in the table and make a conclusion about what the properties of a diode are.
10. Do not forget to answer the two discussions below your observation table!!

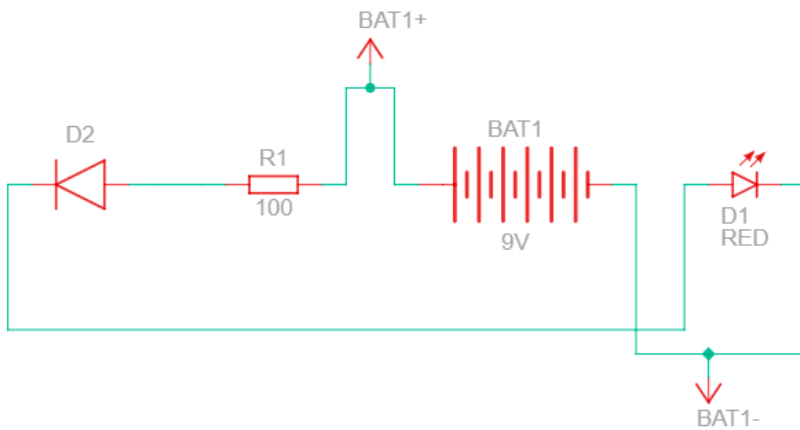
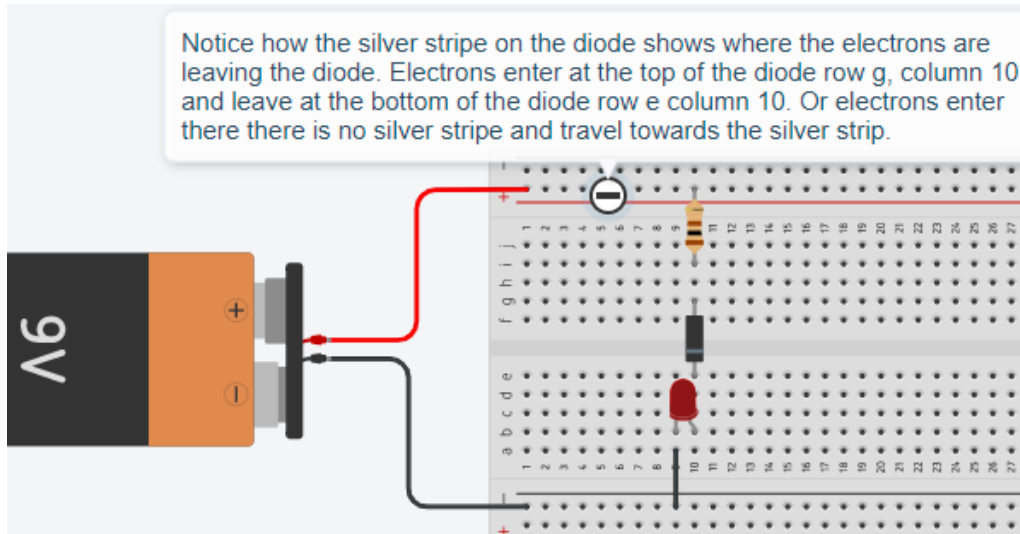

**Observations:**

Location of the silver stripe on the Diode	Is the LED ON or OFF
Silver strip is near the LED (Like example above)	
Silver strip is near the resistor	
Resistor is flipped 180 degrees and Silver stripe is near the LED	
Resistor is flipped 180 degrees and Silver stripe is near the Resistor	
Silver strip is near the LED, and you flip the LED	
Silver strip is near the resistor, and you flip the LED	

**Discussion:**

1. Look up the term polarity with respect to electronic devices (especially the diode, resistor, and LED) and explain in your own words what polarity is.

2. Hypothesize what would happen if you flipped your LED in the lab you just completed. Why do you think that would happen to the LED?

**Conclusion:**

## Lab 2-The Diode Answers

**Purpose:** In this lab the student either alone or in partners (depending on how much electronic equipment you have) will discover the concept of polarity and the properties of several electronic components.

**Materials:**

1. Breadboard
2. Power supply
3. A 100 ohm resistor
4. A 1N 4001 Diode
5. 1 Light emitting Diode (LED)
6. Various wires

**Procedure:**

1. Set up your circuit either using physical items supplied by your teacher or on your device. (Use the example below to assist you)
2. Use a 100 ohm resistor first when you set up your circuit.
3. When you insert your diode into your circuit make sure the end that has the silver strip, is going into the positive (anode) or long leg of the LED. (This is very important)
4. Make an observation on whether or not your LED is on or off. Use the chart below for this.
5. Now, flip your **resistor** 180 degrees. In other words, switch the bottom part of the resistor (row I col 10) with the top rail (where the red wire comes in) and take the top of your resistor and place it in row I col 10.
6. Record what happens to the LED in the table below.
7. Finally flip your Diode 180 degrees, so the silver strip is closer to the resistor. Record your results in the table below.
8. Now, flip your **resistor** 180 degrees. In other words, switch the bottom part of the resistor (row I col 10) with the top rail (where the red wire comes in) and take the top of your resistor and place it in row I col 10.
9. Record your results in the table and make a conclusion about what the properties of a diode are.
10. Do not forget to answer the two discussions below your observation table!!

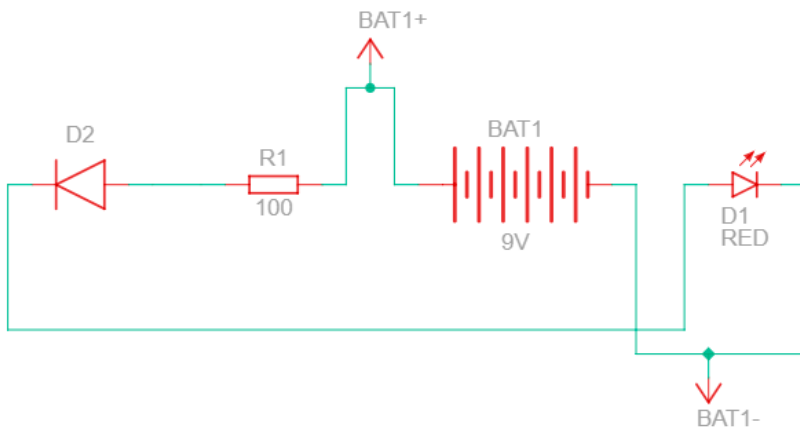
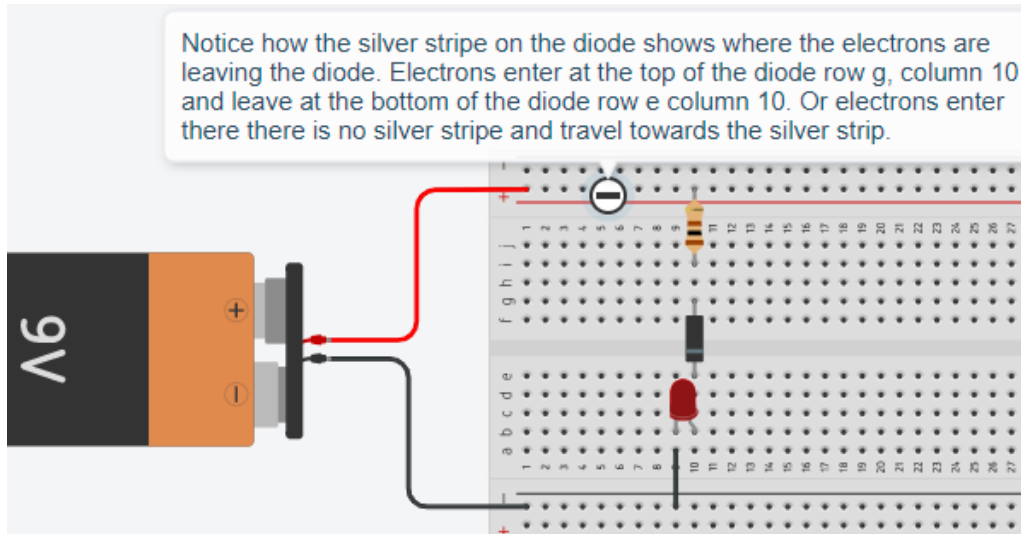

**Observations:**

Location of the silver stripe on the Diode	Is the LED ON or OFF
Silver strip is near the LED (Like example above)	On
Silver strip is near the resistor	Off
Resistor is flipped 180 degrees and Silver stripe is near the LED	On
Resistor is flipped 180 degrees and Silver stripe is near the Resistor	Off
Silver strip is near the LED, and you flip the LED	Off
Silver strip is near the resistor, and you flip the LED	Off

## Discussion:

1. Look up the term polarity with respect to electronic devices (especially the diode, resistor, and LED) and explain in your own words what polarity is.

Polarity means that the device has a positive end and a negative end, like a battery or magnet. If you attempt to put a negative charge on the positive end, the device will not work, and vice versa. A diode has polarity, hence why it would only work when the silver stripe was down (electrons flowed from no stripe to stripe). A resistor, however, does not have polarity, so it does not care how you use it, it will restrict power in any direction. Finally, an LED (light emitting DIODE) is a diode, so it also has polarity. And will only work when you have the long leg (anode) receiving electricity and then the short leg, or cathode, goes to ground.

2. Hypothesize what would happen if you flipped your LED in the lab you just completed. Why do you think that would happen to the LED?

The LED would only work when the silver stripe of the diode is near the long leg of the LED.

**Conclusion:** A diode and an LED have polarity, which means that it matters where you place the legs with respect to the flow of electrons in your circuit. A resistor, however, does not have polarity, so you can use it any way you like.

## Teacher Notes:

The biggest problem with this lab is making sure that the diode is inserted properly and oriented based on the location of the stripe. There have been some challenges with online websites where the polarity of the diode was reversed. So, if your students are doing the labs online, then you might want to try it yourself first and make sure that the diode works correctly.

## Appendix I – Lab 3-The Capacitor

**Purpose:** In this lab the student either alone or in partners (depending on how much electronic equipment you have) will discover the concept of capacitance and the properties of a capacitor.

### Materials:

1. Breadboard
2. Power supply
3. A 1000 ohm resistor
4. A 220 ohm resistor
5. 1 Light emitting Diode (LED)
6. Various wires
7. 1 microfarad polarized capacitor

### Procedure:

1. Set up your circuit either using physical items supplied by your teacher or on your device. (Use the example below to assist you)
2. Does the LED light up? If not, check your polarity (capacitors have capacity also) and connections.
3. Make an observation of the LED. Use the table below for this.
4. Disconnect the power supply (battery) or switch it to off and make an observation of the condition of the LED.
5. Make an observation on how long the LED stays on for. (Count number of seconds)
6. Record your results in the table.
7. Do not forget to answer the 3 discussions below your observation table
8. Make a conclusion about what the properties of a polarized capacitor are.

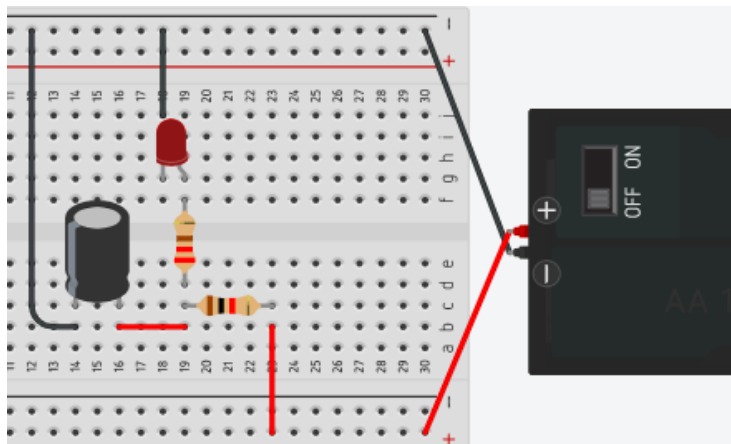

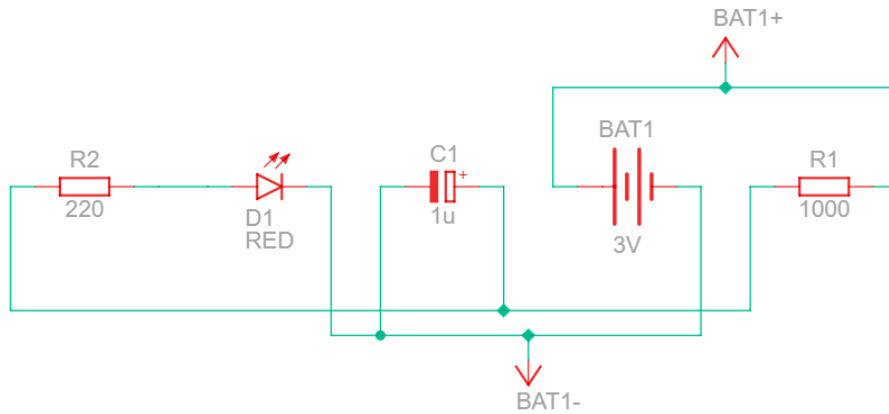

**Observations:**

Set up of the circuit	Is the LED ON or OFF
Circuit is set up the first time.	
Removal of power from the circuit	
How long did the LED stay on after the power was removed?	seconds

**Discussion:**

1. Describe the change in brightness of the LED when the power is removed.
2. Why did the LED continue to glow after the power was removed?
3. What is the difference between a battery and a capacitor?

**Conclusion:**

## Lab 3-The Capacitor Answers

**Purpose:** In this lab the student either alone or in partners (depending on how much electronic equipment you have) will discover the concept of capacitance and the properties of a capacitor.

### Materials:

1. Breadboard
2. Power supply
3. A 1000 ohm resistor
4. A 220 ohm resistor
5. 1 Light emitting Diode (LED)
6. Various wires
7. 1 microfarad polarized capacitor

### Procedure:

1. Set up your circuit either using physical items supplied by your teacher or on your device. (Use the example below to assist you)
2. Does the LED light up? If not, check your polarity (capacitors have capacity also) and connections.
3. Make an observation of the LED. Use the table below for this.
4. Disconnect the power supply (battery) or switch it to off and make an observation of the condition of the LED.
5. Make an observation on how long the LED stays on for. (Count number of seconds)
6. Record your results in the table.
7. Do not forget to answer the 3 discussions below your observation table
8. Make a conclusion about what the properties of a polarized capacitor are.

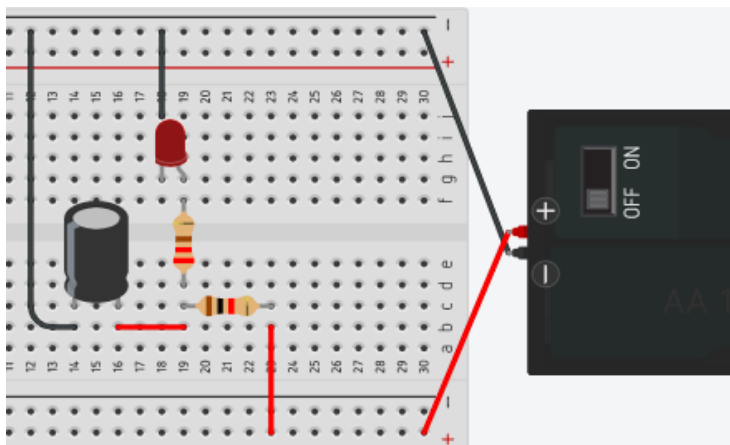

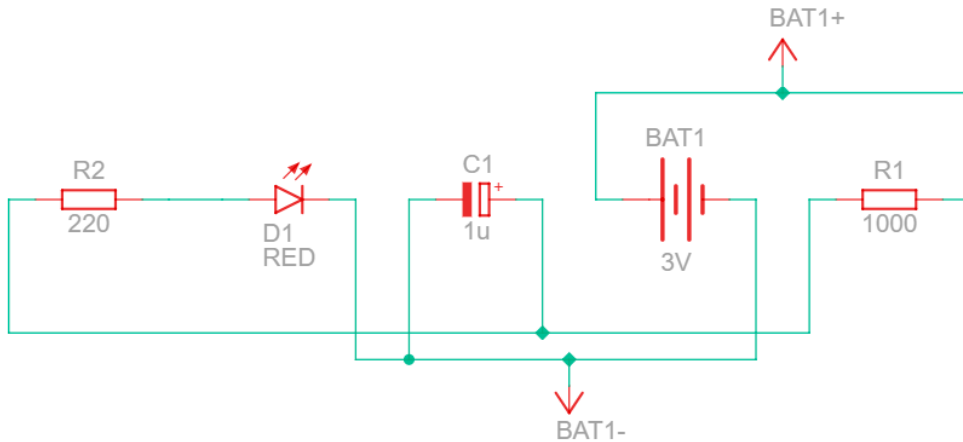

**Observations:**

Set up of the circuit	Is the LED ON or OFF
Circuit is set up the first time.	On
Removal of power from the circuit	Slowly Dims
How long did the LED stay on after the power was removed?	2-7 seconds

**Discussion:**

- Describe the change in brightness of the LED when the power is removed.  
When I remove the power, the LED will start to dim, and over a period of time (2-7) seconds the LED will actually stop shining.
- Why did the LED continue to glow after the power was removed?  
A capacitor becomes the power source for the circuit and uses the stored charge inside of it to power the circuit. However, after a few seconds, the capacitor is discharged, and the LED turns off.
- What is the difference between a battery and a capacitor?  
A battery generates or creates power using a chemical reaction. A capacitor cannot create power but can be charged and will store power. Much like the power packs students use for their cell phones.

**Conclusion:** A capacitor once charged can be used to release power slowly to power a circuit or device.

## Teacher Notes:

The biggest problem with this lab is making sure that the circuit is set up correctly. Also, if students use a non-polarized capacitor, it will work as well. However, I have noticed that often students will get different results on how the capacitor works when they do it online in Tinkercad. If this does happen, have the students delete the capacitor, and put a new one in place, and this usually lets the students see what actually happens. Also, in some cases you can have the students count how long it takes before the LED goes on, which is the “charging” time of the capacitor. Often it will be 1-2 seconds.

You can also replace the capacitor with a 1000uF capacitor. In terms of voltage for the capacitor, as long as the voltage of the capacitor is larger than the voltage you use for the lab, you will be fine.

## Appendix J – Lab 4-The Potentiometer

**Purpose:** In this lab the student either alone or in partners (depending on how much electronic equipment you have) will discover why a potentiometer is also called a variable rate resistor.

### Materials:

1. Breadboard
2. Power supply
3. A 10K ohm Potentiometer
4. 1 Light emitting Diode (LED)
5. Various wires

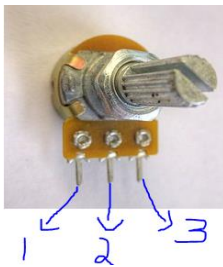

### Procedure:

1. Set up your circuit either using physical items supplied by your teacher or on your device. (Use the example below to assist you)

There are 3 pins on the potentiometer, each pin does something different. When you look at the potentiometer and the handle that rotates is closest to you, the left pin would be called pin 1.

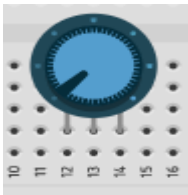

You must also make sure that each pin is in its own separate column. As each pin is an input, and if you put them in a single column, your potentiometer will not work.

2. Connect power to the first pin of the potentiometer, and your LED to the second pin of the potentiometer. (The first pin, is on the Left-hand side, while the knob is point towards you)

3. Make an observation of the condition of the LED as the small silver knob at the front of the Potentiometer is turned both ways. Record your observations in the table below.

4. Now, connect power to the first pin of the potentiometer, and your LED to the 3<sup>rd</sup> pin of the potentiometer. Make an observation of the condition of the LED as the small silver screw on top of the Potentiometer is turned both ways. Record your observations in the table below.

5. Do not forget to answer the 3 discussions below your observation table

6. Make a conclusion about why a potentiometer is also called a variable rate resistor.

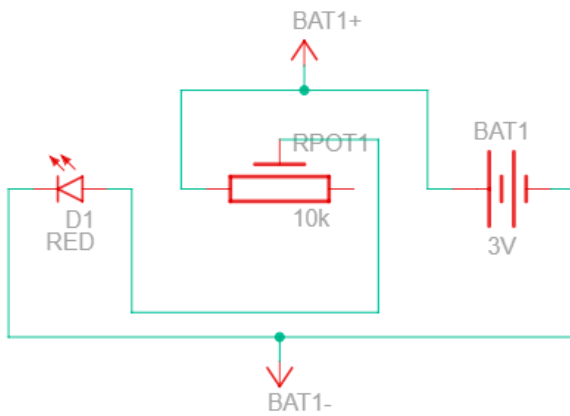
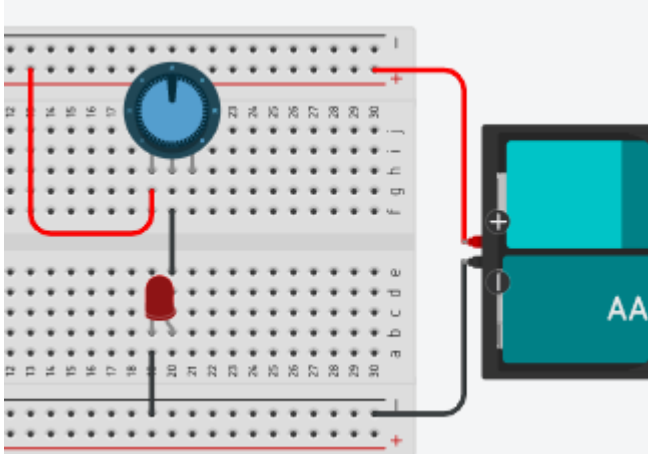

**Observations:**

Pin connection and Turning Direction	LED Observation
Pin 2 connected to LED, Turn Clockwise	
Pin 2 connected to LED, Turn Counter Clockwise	
Pin 3 connected to LED, Turn Clockwise	
Pin 3 connected to LED, Turn Counter Clockwise	

**Discussion:**

1. Describe the change in brightness of the LED when it is connected to the 2<sup>nd</sup> pin of the Potentiometer as it is turned:

Clockwise:

Counter Clockwise:

2. Which pin on the Potentiometer did you have to use to get the potentiometer to act like a variable rate resistor?

3. People use potentiometers everywhere. Give an example of where you would find a potentiometer being used where you live?

**Conclusion:**

**References:**

[https://commons.wikimedia.org/wiki/File:20K\\_Potentiometer\\_1480316\\_7\\_8Enhancer.jpg](https://commons.wikimedia.org/wiki/File:20K_Potentiometer_1480316_7_8Enhancer.jpg)

## Lab 4-The Potentiometer Answers

**Purpose:** In this lab the student either alone or in partners (depending on how much electronic equipment you have) will discover why a potentiometer is also called a variable rate resistor.

### Materials:

1. Breadboard
2. Power supply
3. A 10K ohm Potentiometer
4. 1 Light emitting Diode (LED)
5. Various wires

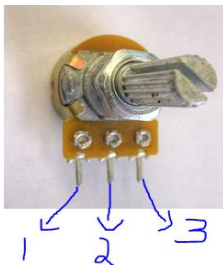

### Procedure:

1. Set up your circuit either using physical items supplied by your teacher or on your device. (Use the example below to assist you

There are 3 pins on the potentiometer, each pin does something different. When you look at the potentiometer and the handle that rotates is closest to you, the left pin would be called pin 1.



You must also make sure that each pin is in its own separate column. As each pin is an input, and if you put them in a single column, your potentiometer will not work.

2. Connect power to the first pin of the potentiometer, and your LED to the second pin of the potentiometer. (The first pin, is on the Left-hand side, while the knob is point towards you)
3. Make an observation of the condition of the LED as the small silver knob at the front of the Potentiometer is turned both ways. Record your observations in the table below.
4. Now, connect power to the first pin of the potentiometer, and your LED to the 3<sup>rd</sup> pin of the potentiometer. Make an observation of the condition of the LED as the small silver screw on top of the Potentiometer is turned both ways. Record your observations in the table below.
5. Do not forget to answer the 3 discussions below your observation table
6. Make a conclusion about why a potentiometer is also called a variable rate resistor.

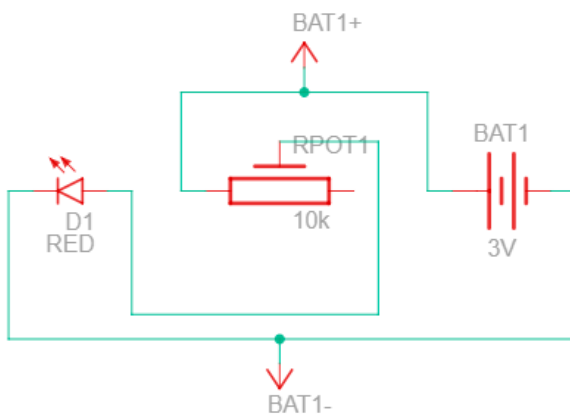
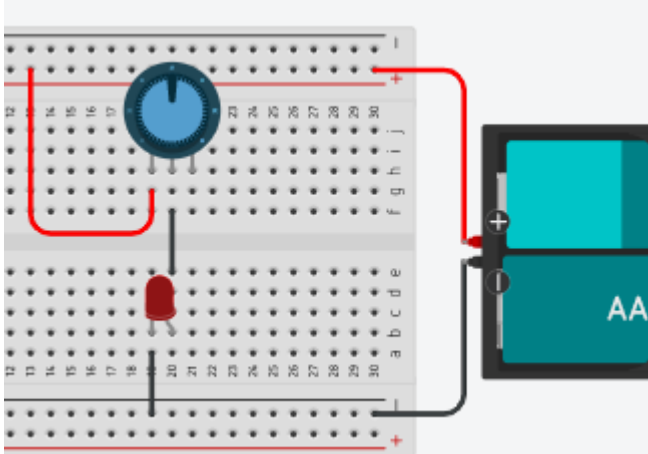

**Observations:**

Pin connection and Turning Direction	LED Observation
Pin 2 connected to LED, Turn Clockwise	Gets dimmer
Pin 2 connected to LED, Turn Counter Clockwise	Gets brighter
Pin 3 connected to LED, Turn Clockwise	No change, stays dim
Pin 3 connected to LED, Turn Counter Clockwise	No change, stays dim

**Discussion:**

1. Describe the change in brightness of the LED when it is connected to the 2<sup>nd</sup> pin of the Potentiometer as it is turned:

Clockwise: The LED will get brighter, until it burns out.

Counter Clockwise: The LED will get dimmer until it turns off and has no visible light

2. Which pin on the Potentiometer did you have to use to get the potentiometer to act like a variable rate resistor?

You must use pin 2, as pin 2 is the “wiper” in the potentiometer. In other words, pin 2 acts like a variable rate resistor, increasing and decreasing the resistance in the circuit, which makes the LED get dimmer or brighter.

Pin 3 applies the full value of the potentiometer to the circuit. Since we are using a 10K ohm potentiometer, the circuit is receiving 10 000 ohms of resistance when we connect to pin 3. The turning of the wiper blade does nothing in this case and is only valid when you attach your output to pin 2.

3. People use potentiometers everywhere. Give an example of where you would find a potentiometer being used where you live?

Dimmer switch, how toasted you want your bread, speakers or radios with volume knobs that turn. The oven and stove knobs to turn on the burners, etc.

**Conclusion:** A potentiometer is called a variable rate resistor because when you connect your output to pin 2, you can vary or change the amount of resistance you want to apply to your output, or circuit. However, if you connect your output to pin 3, your potentiometer acts like a regular resistor.

## Teacher Notes

In some online programs the pin order of the potentiometer might be reversed. The best option is to check and look to see what the pin says. On an actual potentiometer, you will see V in which is pin 1, or where you apply voltage, the middle pin will always be the variable or wiper pin, and then if you see V out, that would be the pin you use to achieve the full resistance of the potentiometer. The rating of the potentiometer (ohms) can vary; it all depends on what you want to buy or use. However, the smaller the rating on the potentiometer, the more control you will have, since the “scale” of the wiper blade will be smaller and more accurate.

## Appendix K – Activity 1 What is Electricity Lesson Plan

<p><b>TEACHER:</b> <b>GRADE:</b> 9 Integrated Technology</p>	<p><b>CURRICULUM SUBJECT:</b> TIJ 10 <b>UNIT:</b>1</p>
<p><b>LESSON TOPIC:</b> What is electricity?</p>	<p><b>MATERIALS/ VISUAL AIDS:</b></p> <ul style="list-style-type: none"> <li>● Calculator</li> <li>● Ohm’s law image formula</li> </ul>
<p><b>INTRODUCTION/ MOTIVATION:</b> How does electricity power our modern world?</p>	<p><b>PERFORMANCE CRITERIA (STUDENTS EXPECTATIONS):</b> Students will be required to understand the basic concepts of electricity, its values and how to measure it.</p>
<p><b>EXPECTATIONS:</b></p> <ul style="list-style-type: none"> <li>● B2.5, C2.1</li> </ul>	<p><b>MATERIALS/ VISUAL AIDS:</b></p> <ul style="list-style-type: none"> <li>● Calculator</li> <li>● Copies of assignment</li> <li>● Copy of PowerPoint</li> </ul>
<p><b>TEACHING/ LEARNING CONTENT:</b></p> <ul style="list-style-type: none"> <li>● Use a projector or share your computer screen to present the What is Electricity PowerPoint.</li> <li>● Discuss the measurement and symbols used when working with electricity.</li> <li>● Demonstrate some examples on how to use and calculate Ohm’s law.</li> <li>● Allow time for questions or concerns</li> <li>● Distribute student assignments</li> <li>● Provide time for students to begin assignment</li> </ul>	
<p><b>SUMMARY/ RECAPITULATION:</b> Without electricity, our modern world would grind to a halt, leaving many people desperate for their basic necessities.</p>	
<p><b>EVALUATION/ ASSIGNMENT:</b> Students are required to complete the What is Electricity worksheet and submit it for marking. This material will also be tested in the What is Electricity quiz.</p>	
<p><b>LESSON NOTES/ REFLECTION:</b></p>	

## Appendix L - Activity 2 –Electronic Components Lesson Plan

<b>TEACHER:</b> <b>GRADE:</b> 9 Integrated Technology	<b>CURRICULUM SUBJECT:</b> TIJ 10 <b>UNIT:</b> 1
<b>LESSON TOPIC:</b> Electronic components?	<b>MATERIALS/ VISUAL AIDS:</b> <ul style="list-style-type: none"> <li>● Students will need access to the internet for this lesson</li> </ul>
<b>INTRODUCTION/ MOTIVATION:</b> Students are given the electronics components assignment, which is like a scavenger hunt.	<b>PERFORMANCE CRITERIA (STUDENTS EXPECTATIONS):</b> Students will be required to understand the basic electronic components, how they work and how they are used.
<b>EXPECTATIONS:</b> <ul style="list-style-type: none"> <li>● A1.1</li> </ul>	<b>MATERIALS/ VISUAL AIDS:</b> <ul style="list-style-type: none"> <li>● Copies of assignment</li> <li>● Copy of PowerPoint</li> </ul>
<b>TEACHING/ LEARNING CONTENT:</b> <b>Day 1:</b> <ul style="list-style-type: none"> <li>● Give out the electronic component assignment and encourage the students to complete it using the internet. (full class)</li> <li>● Go over any questions and decide if you wish to collect this for assessment or evaluation.</li> <li>● Provide time for students to begin and complete assignment</li> </ul> <b>Day 2:</b> <ul style="list-style-type: none"> <li>● Use a projector or share your computer screen to present the Electronic Component PowerPoint.</li> <li>● Discuss the electrical components, as well as AC and DC Power.</li> <li>● Allow time for questions or concerns</li> </ul>	
<b>SUMMARY/ RECAPITULATION:</b> Every electrical device that you have or have seen is made up with the electronic components we have learned about today. Take grade 10, 11 and 12 Computer Engineering to learn more.	
<b>EVALUATION/ ASSIGNMENT:</b> Students are required to complete the electronic component worksheet and submit it for marking.	
<b>LESSON NOTES/ REFLECTION:</b>	

## Appendix M - Activity 3 –Resistors and how to classify them Lesson Plan

<b>TEACHER:</b> <b>GRADE:</b> 9 Integrated Technology	<b>CURRICULUM SUBJECT:</b> TIJ 10 <b>UNIT:</b> 1
<b>LESSON TOPIC:</b> Resistors and how to classify them	<b>MATERIALS/ VISUAL AIDS:</b> <ul style="list-style-type: none"> <li>● Students will need a copy of the Resistor Classification Table.</li> </ul>
<b>INTRODUCTION/ MOTIVATION:</b> How does an oven or stove or toaster heat up the element, so it is red hot? Resistance, that is how!	<b>PERFORMANCE CRITERIA (STUDENTS EXPECTATIONS):</b> Students will be given various types of resistors and must be able to successfully state their resistance and tolerance. Students will be given various resistance values and be expected to successfully state the colour bands of the resistor.
<b>EXPECTATIONS:</b> <ul style="list-style-type: none"> <li>● A1.1, B2.5</li> </ul>	<b>MATERIALS/ VISUAL AIDS:</b> <ul style="list-style-type: none"> <li>● Copies of assignments</li> <li>● Copy of PowerPoint</li> <li>● Copies of quiz</li> </ul>
<b>TEACHING/ LEARNING CONTENT:</b> <b>Day 1:</b> <ul style="list-style-type: none"> <li>● Use a projector or share your computer screen to present the Resistor PowerPoint. Stop just before the converting resistance to its coloured bands.</li> <li>● Go over the Resistor Classification Table</li> <li>● Demonstrate how to classify a resistor.</li> <li>● Allow time for questions or concerns</li> <li>● Give out the Resistor Worksheet 1 assignment and encourage the students to complete it.</li> <li>● Provide time for students to begin and complete assignment</li> <li>● Allow time for questions or concerns</li> </ul> <p>(continued on next page)</p>	

**Day 2:**

- Take up any questions to Resistor Worksheet 1.
- Use a projector or share your computer screen to finish presenting the electronic component PowerPoint.
- Demonstrate how to classify a resistance value and convert it to a resistor.
- Give out the Resistor Worksheet 2 assignment and encourage the students to complete it.
- Provide time for students to begin and complete assignment
- Allow time for questions or concerns

**SUMMARY/ RECAPITULATION:**

Without resistance we would not be able to easily cook our food, regulate how toasted we want our bread, or limit voltage in our electronic devices.

**EVALUATION/ ASSIGNMENT:**

Students are required to complete both Resistor Worksheets and then you can give them the Resistor Quiz.

**LESSON NOTES/ REFLECTION:**

## Appendix N - Activity 4 –Electronic Labs Lesson Plan

<p><b>TEACHER:</b> <b>GRADE:</b> 9 Integrated Technology</p>	<p><b>CURRICULUM SUBJECT:</b> TIJ 10 <b>UNIT:</b>1</p>
<p><b>LESSON TOPIC:</b> Students will apply what they have learned from the past 2 lesson's by creating 4 electronic labs.</p>	<p><b>MATERIALS/ VISUAL AIDS:</b></p> <ul style="list-style-type: none"> <li>● Students will need a copy of the Resistor Classification Table.</li> <li>● Students will need access to either software or a webpage that allows them to build their circuit. Or the actual items that they can build their circuit with. (See labs for material list)</li> </ul>
<p><b>INTRODUCTION/ MOTIVATION:</b> Today, you are going to tinker, explore and play with all the electronic components you have been learning about. You will also apply what you have learned about Ohm's law, and electricity. Have fun, be safe, and ask lots of questions.</p>	<p><b>PERFORMANCE CRITERIA (STUDENTS EXPECTATIONS):</b> Students will be given the labs and the materials necessary to build them. Students will be expected to answer the questions in the labs.</p>
<p><b>EXPECTATIONS:</b></p> <ul style="list-style-type: none"> <li>● A1.1, B2.1,</li> </ul>	<p><b>MATERIALS/ VISUAL AIDS:</b></p> <ul style="list-style-type: none"> <li>● Copies of labs</li> <li>● Necessary equipment for the labs.</li> </ul>
<p><b>TEACHING/ LEARNING CONTENT:</b></p> <p><b>Day 1:</b></p> <ul style="list-style-type: none"> <li>● Depending on which option you will use to do the labs, you may have to provide training on how to use the software, or how to access and use the electronic components and items.</li> <li>● Provide time for students to begin and complete labs (1 and 2)</li> <li>● Allow time for questions or concerns</li> <li>● Allow time for students to put equipment away before the end of class.</li> </ul> <p><b>Day 2:</b></p> <ul style="list-style-type: none"> <li>● Students will continue to work on unfinished labs, and then complete labs 3 and 4.</li> <li>● Demonstrate how to classify a resistance value and convert it to a resistor.</li> <li>● Provide time for students to begin and complete assignment</li> <li>● Allow time for questions or concerns</li> <li>● Allow time for students to put equipment away before the end of class.</li> </ul>	

**SUMMARY/ RECAPITULATION:**

How was your first day of building a simple circuit? Imagine how complicated the circuitry in your phone, or devices around your house are?

**EVALUATION/ ASSIGNMENT:**

Students are required to complete the 4 electronic labs and submit them for assessment.

**LESSON NOTES/ REFLECTION:**

## Appendix O - Activity 5 –Final Project Lesson Plan

<p><b>TEACHER:</b> <b>GRADE:</b> 9 Integrated Technology</p>	<p><b>CURRICULUM SUBJECT:</b> TIJ 10 <b>UNIT:</b>1</p>
<p><b>LESSON TOPIC:</b> Students will apply everything they have learned from all the lessons in this unit to build something cool and interesting.</p>	<p><b>MATERIALS/ VISUAL AIDS:</b></p> <ul style="list-style-type: none"> <li>● Materials required for the project</li> <li>● A copy of the requirements for the project.</li> </ul>
<p><b>INTRODUCTION/ MOTIVATION:</b> Today, you are going to tinker, explore and play with all the electronic components you have been learning about. You will build something cool that you can show off to the school and your friends.</p>	<p><b>PERFORMANCE CRITERIA (STUDENTS EXPECTATIONS):</b> Students will be given the assignment and the materials necessary to build their project.</p>
<p><b>EXPECTATIONS:</b></p> <ul style="list-style-type: none"> <li>● A1.1, B2.1,</li> </ul>	<p><b>MATERIALS/ VISUAL AIDS:</b></p> <ul style="list-style-type: none"> <li>● Copies of project</li> <li>● Necessary equipment for the project.</li> </ul>
<p><b>TEACHING/ LEARNING CONTENT:</b></p> <p><b>Day 1:</b></p> <ul style="list-style-type: none"> <li>● Go over the project details and discuss with the students the expectations and how the project will be assessed.</li> <li>● Students will start with their outline for their project, and then begin to follow the instructions in the project.</li> <li>● Provide time for students to begin and complete assignment</li> <li>● Allow time for questions or concerns</li> <li>● Allow time for students to put equipment away before the end of class.</li> </ul> <p><b>Day 2:</b></p> <ul style="list-style-type: none"> <li>● Students will continue to work on the project.</li> <li>● Provide time for students to begin and complete assignment</li> <li>● Allow time for questions or concerns</li> <li>● Allow time for students to put equipment away before the end of class.</li> </ul> <p><b>Day 3:</b></p> <ul style="list-style-type: none"> <li>● Students will continue to work on the project and finish it today.</li> <li>● Allow time for questions or concerns</li> <li>● Allow time for students to put equipment away before the end of class.</li> </ul>	

**SUMMARY/ RECAPITULATION:**

Students will submit their write up for the assignment, and you can then display their final projects to the school.

**EVALUATION/ ASSIGNMENT:**

Students are required to complete the project and submit them for assessment.

**LESSON NOTES/ REFLECTION:**

## References

20K Potentiometer, Wikimedia (picture) 2022

[https://commons.wikimedia.org/wiki/File:20K\\_Potentiometer\\_1480316\\_7\\_8Enhancer.jpg](https://commons.wikimedia.org/wiki/File:20K_Potentiometer_1480316_7_8Enhancer.jpg)

21<sup>st</sup> Century Competencies: Foundation Document for Discussion. Phase 1: Towards Defining 21<sup>st</sup> Century Competencies for Ontario, Winter 2016 Edition, 2016

[http://www.edugains.ca/resources21CL/About21stCentury/21CL\\_21stCenturyCompetencies.pdf](http://www.edugains.ca/resources21CL/About21stCentury/21CL_21stCenturyCompetencies.pdf)

Assignment on electronic components, OCTE, 2022

<https://docs.google.com/document/d/1EWHR-7J8gYrw5ixaYUiwL-LARf4hgZZg/edit?usp=sharing&oid=100164637603266593663&rtpof=true&sd=true>

Assignment on electronic components solutions, OCTE, 2022,

<https://docs.google.com/document/d/1zqOhsdmDrh2pZjWJVs695GfRGOK0KWmr/edit?usp=sharing&oid=100164637603266593663&rtpof=true&sd=true>

Coffins (picture), 2022 [https://drive.google.com/file/d/17-](https://drive.google.com/file/d/17-8dMS1kB5g8MgzdVccYV1GiNrLCeEH/view?usp=sharing)

[8dMS1kB5g8MgzdVccYV1GiNrLCeEH/view?usp=sharing](https://drive.google.com/file/d/17-8dMS1kB5g8MgzdVccYV1GiNrLCeEH/view?usp=sharing)

Course Codes for Emphasis courses in the Revised Curriculum: Technological Education, Grades 11 and 12, 2009

<http://www.edu.gov.on.ca/eng/curriculum/secondary/techedemphasiscourses.pdf>

Easter Bunny (picture), 2022 [https://drive.google.com/file/d/1-kFcDCczZUra-](https://drive.google.com/file/d/1-kFcDCczZUra-WE3X9GueXb_2fl4x82u/view)

[WE3X9GueXb\\_2fl4x82u/view](https://drive.google.com/file/d/1-kFcDCczZUra-WE3X9GueXb_2fl4x82u/view)

Easter Image 1 (picture), 2022 [https://drive.google.com/file/d/1qszYZwX\\_AUqGQPbV-](https://drive.google.com/file/d/1qszYZwX_AUqGQPbV-01NdnPib0bLeURT/view?usp=sharing)

[01NdnPib0bLeURT/view?usp=sharing](https://drive.google.com/file/d/1qszYZwX_AUqGQPbV-01NdnPib0bLeURT/view?usp=sharing)

Easter Image 2 (picture), 2022

<https://drive.google.com/file/d/1Qc6uiOsOLqrsve3TbuP7OY9ABrsyzZ1l/view?usp=sharing>

Easter Image 3 (picture), 2022

[https://drive.google.com/file/d/1QGknt4xi2GOMeKxZ6Cj\\_AIEMHZe7lrlU/view?usp=sharing](https://drive.google.com/file/d/1QGknt4xi2GOMeKxZ6Cj_AIEMHZe7lrlU/view?usp=sharing)

Education and Training <https://www.ontario.ca/page/education-and-training>

Electronic Components PowerPoint, OCTE (presentation), 2022

[https://docs.google.com/presentation/d/1eiUfb4IRJ76pWn3cfNmx\\_AZFcijkSWFC/edit?usp=sharing&oid=100164637603266593663&rtpof=true&sd=true](https://docs.google.com/presentation/d/1eiUfb4IRJ76pWn3cfNmx_AZFcijkSWFC/edit?usp=sharing&oid=100164637603266593663&rtpof=true&sd=true)

Fuzzy Pumpkin (picture), 2022

<https://drive.google.com/file/d/16pU56j2hW7G6axDVbBmUdvh8ajNJOeGa/view?usp=sharing>

Growing Success: Assessment, Evaluation, and Reporting in Ontario Schools, First Edition, Covering Grades 1 to 12, 2010

[www.edu.gov.on.ca/eng/policyfunding/growSuccess.pdf](http://www.edu.gov.on.ca/eng/policyfunding/growSuccess.pdf)

Halloween 1 (picture), 2022 <https://drive.google.com/file/d/1VlcfPdSfBmX-67MVacpASGMSN3gJ958q/view?usp=sharing>

Halloween 2 (picture), 2022

<https://drive.google.com/file/d/1SRAYGIDlw7zvwsyjessv0v3129BNeZoY/view>

Lab 1 The Resistor, OCTE, 2022,

[https://docs.google.com/document/d/1nwYGbYwtNv40bwitjXNoEj\\_LdlL-ol6M/edit?usp=sharing&oid=100164637603266593663&rtpof=true&sd=true](https://docs.google.com/document/d/1nwYGbYwtNv40bwitjXNoEj_LdlL-ol6M/edit?usp=sharing&oid=100164637603266593663&rtpof=true&sd=true)

Lab 1 The Resistor Teacher Solution and Read Me, OCTE, 2022

<https://docs.google.com/document/d/17RMWzicacnXF9MGNZ88hSuBcE3AcWlcW/edit?usp=sharing&oid=100164637603266593663&rtpof=true&sd=true>

Lab 2 The Diode, OCTE, 2022

[https://docs.google.com/document/d/1EUl4\\_K2ebrdPmOtDer5fb6uEURjFBIsI/edit?usp=sharing&oid=100164637603266593663&rtpof=true&sd=true](https://docs.google.com/document/d/1EUl4_K2ebrdPmOtDer5fb6uEURjFBIsI/edit?usp=sharing&oid=100164637603266593663&rtpof=true&sd=true)

Lab 2 The Diode Teacher Solution and Read Me, OCTE, 2022

<https://docs.google.com/document/d/1OFmGtrdVYph8bo2x8kwC0KWFubBMqovw/edit?usp=sharing&oid=100164637603266593663&rtpof=true&sd=true>

Lab 3 The Capacitor, OCTE, 2022

<https://docs.google.com/document/d/11EddOilyMWxglFBdWRjkEYb9JRIMBqel/edit?usp=sharing&oid=100164637603266593663&rtpof=true&sd=true>

Lab 3 The Capacitor Teacher Solution and Read Me, OCTE, 2022

<https://docs.google.com/document/d/1-ChLTnZnNrETZa9Pamt5ehmwvX1zBTdd/edit?usp=sharing&oid=100164637603266593663&rtpof=true&sd=true>

Lab 4 The Potentiometer, OCTE, 2022 <https://docs.google.com/document/d/1f1UjEaZ1T-BaHNAmjmfe1d3Ds1bYj2mR/edit?usp=sharing&oid=100164637603266593663&rtpof=true&sd=true>

<https://docs.google.com/document/d/1f1UjEaZ1T-BaHNAmjmfe1d3Ds1bYj2mR/edit?usp=sharing&oid=100164637603266593663&rtpof=true&sd=true>

Lab 4 The Potentiometer Teacher Solution and Read Me, OCTE, 2022

<https://docs.google.com/document/d/1a9PgG8sVQS9V2s7MxAPi43iixpgEOVY-/edit?usp=sharing&oid=100164637603266593663&rtpof=true&sd=true>

Learning for All – A Guide to Effective Assessment and Instruction for All Students, Kindergarten to Grade 12, <https://www.dcp.edu.gov.on.ca/en/>

Learning Goals and Success Criteria Viewing Guide, Government of Ontario (pdf), 2011 <http://www.edugains.ca/resourcesAER/VideoLibrary/LearningGoalsSuccessCriteria/LearningGoalsSuccessCriteriaViewingGuide2011.pdf>

OCTE SAFEDocs for BBT Technology, OCTE (website), 2022 <https://www.octe.ca/en/resources/safety/safedocs>

Red SEAL – Sceau Rouge, 2018 [http://www.red-seal.ca/trades/tr.1d.2s\\_l.3st-eng.html](http://www.red-seal.ca/trades/tr.1d.2s_l.3st-eng.html)

Resistor classification table, OCTE, 2022 <https://drive.google.com/file/d/1hOFQZQq2PeY79dbDbSFkIOUlyILXEr-/view?usp=sharing>

Resistors PowerPoint, OCTE (presentation), 2022 <https://docs.google.com/presentation/d/1jmDSOWV8y-FX5ddE4K-LeZSgV-VRFAnJ/edit?usp=sharing&oid=100164637603266593663&rtpof=true&sd=true>

Resistor Quiz, OCTE (quiz), 2022 <https://docs.google.com/document/d/1HtOH6Sr2CSkhTUWJJshJrZSHMW78xXa7/edit?usp=sharing&oid=100164637603266593663&rtpof=true&sd=true>

Resistor Quiz Solutions, OCTE, 2022 <https://docs.google.com/document/d/1-U5jUMBWvEvpCHv11v0YzITy7PVwBtTt/edit?usp=sharing&oid=100164637603266593663&rtpof=true&sd=true>

Resistor Worksheet 1, OCTE (worksheet), 2022 [https://docs.google.com/document/d/1ENYs6PFt\\_0ssa2UbfA924nfkc4q9kXII/edit?usp=sharing&oid=100164637603266593663&rtpof=true&sd=true](https://docs.google.com/document/d/1ENYs6PFt_0ssa2UbfA924nfkc4q9kXII/edit?usp=sharing&oid=100164637603266593663&rtpof=true&sd=true)

Resistor Worksheet 1 Solutions, OCTE, 2022, <https://docs.google.com/document/d/1scfsqzaycRgYBLMHNHuXJpnPN5kkJwTc/edit?usp=sharing&oid=100164637603266593663&rtpof=true&sd=true>

Resistor Worksheet 2, OCTE (worksheet), 2022 <https://docs.google.com/document/d/1UUc8WP6-NSe0NXAtjuUYFISl4ta4Jl4b/edit?usp=sharing&oid=100164637603266593663&rtpof=true&sd=true>

Resources, Skilled Trades Ontario <https://www.skilledtradesontario.ca/about-trades/trades-information/Start an Apprenticeship in Ontario>  
<https://www.ontario.ca/page/start-apprenticeship>

SafetyNET TEJ Breadboard And Circuits Lab, OCTE, 2022

<https://www.octe.ca/en/resources/resource-folder/safetydocs/tej-safetydocs/safetynet-tej-breadboard-and-circuits-lab>

Skeleton Nuclear Waste (picture), 2022

<https://drive.google.com/file/d/1SRAYGIDlw7zvwsyessv0v3129BNeZoY/view?usp=sharing>

Skilled Trades Identified in Ontario, Skilled Trades Ontario

<https://www.skilledtradesontario.ca/about-trades/trades-information/>

Skilled Trades Ontario <https://www.skilledtradesontario.ca>

Spooky Bucket (picture), 2022 <https://drive.google.com/file/d/1uIRILhdXhaRTh-B2SB3r5u6t6wrj6SpO/view?usp=sharing>

The Differentiated Instruction Scrapbook

<http://www.edugains.ca/resources/DI/EducatorsPackages/DIEducatorsPackage2010/2010/DIScrapbook.pdf>

The Ontario Curriculum, Grades 9 and 10: Technological Education, 2009 (revised)

<http://www.edu.gov.on.ca/eng/curriculum/secondary/teched910curr09.pdf>

ToolSAFE TEJ Electronic Circuit Designing, OCTE (video), 2017,

<https://www.octe.ca/en/resources/resource-folder/safetydocs/tej-safetydocs/toolsafe-tej-electronic-circuit-designing>

ToolSAFE TEJ Wire Stripping and Crimping, OCTE (video), 2017

<https://www.octe.ca/en/resources/resource-folder/safetydocs/tej-safetydocs/toolsafe-tej-wire-stripping-and-crimping>

What is Electricity Assessment, OCTE (quiz), 2022

[https://docs.google.com/document/d/1Qo1KA1lof6vnPT8ysjO2on\\_0yu7hCzr/edit?usp=sharing&oid=100164637603266593663&rtpof=true&sd=true](https://docs.google.com/document/d/1Qo1KA1lof6vnPT8ysjO2on_0yu7hCzr/edit?usp=sharing&oid=100164637603266593663&rtpof=true&sd=true)

What is Electricity Assessment Solution, OCTE, 2022

[https://docs.google.com/document/d/1jDto8pX9vSYRH\\_8eZ2HRm3WBtEIV0gP8/edit?usp=sharing&oid=100164637603266593663&rtpof=true&sd=true](https://docs.google.com/document/d/1jDto8pX9vSYRH_8eZ2HRm3WBtEIV0gP8/edit?usp=sharing&oid=100164637603266593663&rtpof=true&sd=true)

What is Electricity Assignment Solution, OCTE, 2022

[https://docs.google.com/document/d/1gHFvHi3b2PGWNbdH\\_FUiwD95bL5JsCd/edit?usp=sharing&oid=100164637603266593663&rtpof=true&sd=true](https://docs.google.com/document/d/1gHFvHi3b2PGWNbdH_FUiwD95bL5JsCd/edit?usp=sharing&oid=100164637603266593663&rtpof=true&sd=true)

What is Electricity PowerPoint, OCTE, 2022

<https://docs.google.com/presentation/d/1WUq7C5EmmkARno6zyJ2Va57d1rVTdodX/edit?usp=sharing&oid=100164637603266593663&rtpof=true&sd=true>

What is Electricity Student Assignment, OCTE, 2022

<https://docs.google.com/document/d/1T32KTbCy8kQr8HqXTBRD5tu1qSCkzHpD/edit?usp=sharing&oid=100164637603266593663&rtpof=true&sd=true>